

Covered Rail Cars

- Cut sheets for two possible rail cars are included.

ORIGINAL COVER



COVER OPEN



HAND HOLDS COVERED IN SILO



END CAP OVER HAND HOLDS

FARING & DOOR

S-2044

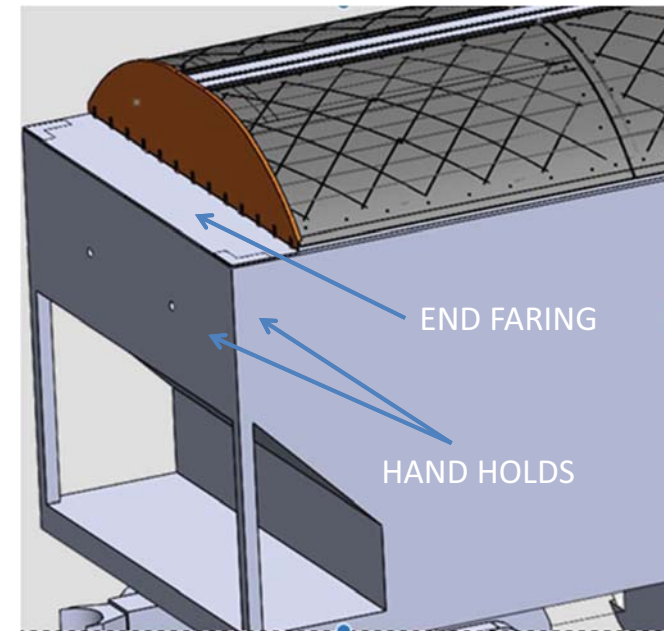

END FARING

HAND HOLDS

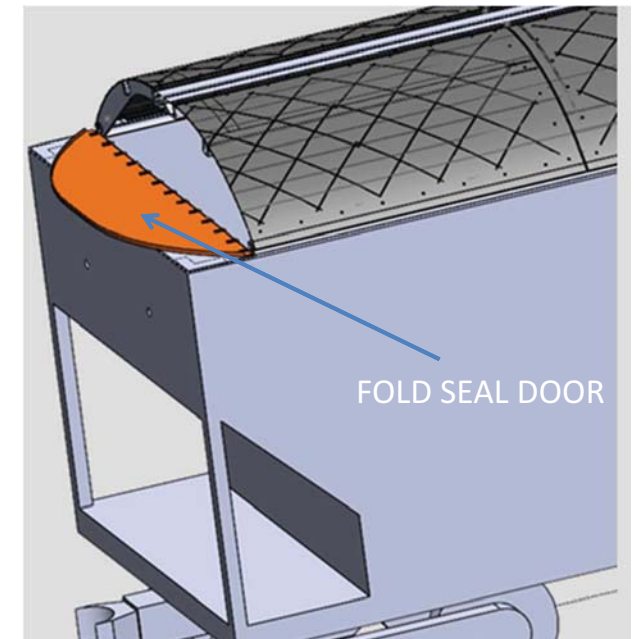

FOLD SEAL DOOR

COVER OPEN TO LOAD CLEARS HAND HOLDS

CLEAR HAND HOLDS

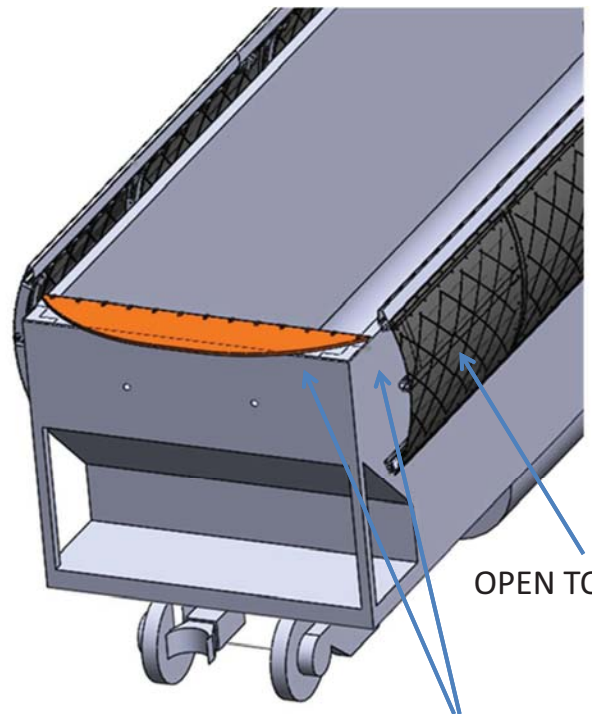
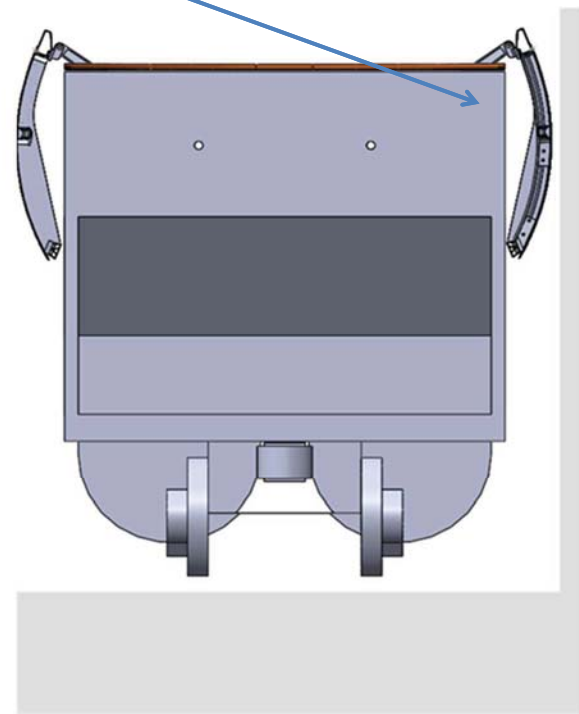

OPEN TO LOAD

CLEAR HAND HOLDS

DOOR OPEN TO LOAD

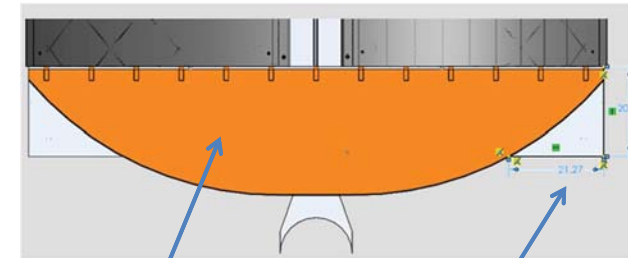

SEAL DOOR

CLEAR HAND HOLDS

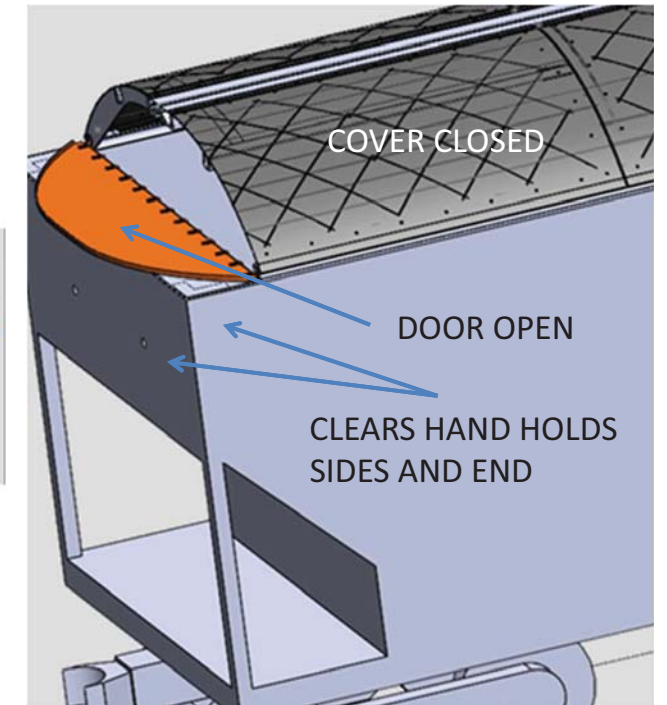

COVER CLOSED

DOOR OPEN

CLEAR HAND HOLDS
SIDES AND END

CLOSED & LOADING

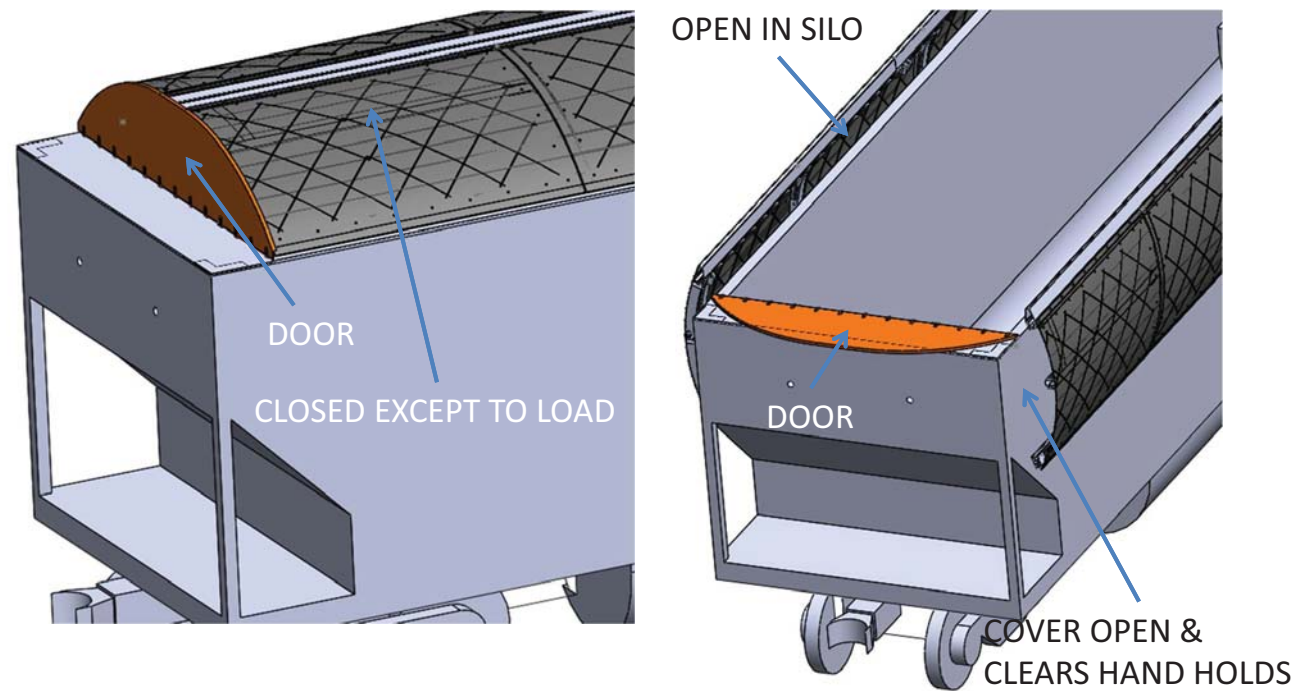

DRIVE CYLINDERS ON THE END

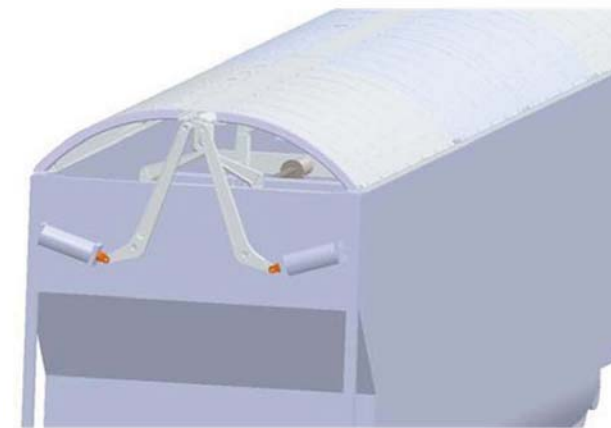

- CAN NOT COVER THE HAND HOLDS
- MAY NEED TO PUT DRIVE INSIDE THE CAR



4250 COVERED HOPPER

DIMENSIONS (APPROX.)

LENGTH, INSIDE	42' 8 1/8"
LENGTH, OVER COUPLERS	47' 10"
LENGTH, BETWEEN TRUCK CENTERS	35' 3 1/2"
HEIGHT, EXTREME	15' 6"
WIDTH, EXTREME	10' 8"
DISCHARGE GATE SIZE	30" X 30"
HATCH OPENING	34' 6"
CLEARANCE	AAR PLATE C

WEIGHT/CAPACITY (EST.)

LIGHT WEIGHT	57,000 LBS.
GROSS RAIL LOAD	286,000 LBS.
LOAD LIMIT	229,000 LBS.
CUBIC CAPACITY	4,250 CU. FT.

CURVE NEGOTIABILITY RADIUS

UNCOUPLED	150'
COUPLED TO LIKE CAR	199'
COUPLED TO BASE CAR	197'

DESIGNED AND BUILT TO AAR SPECIFICATION FOR M-1001

THESE GENERAL DIMENSIONS ARE REPRESENTATIVE AND SUBJECT TO CHANGE WITHOUT NOTICE AS REQUIRED BY CUSTOMER SPECIFICATIONS OR DESIGN IMPROVEMENTS BY THE GREENBRIER COS.

SODA ASH AND POTASH SERVICE

This 4,250 cubic foot capacity covered hopper car is a curve-sided design with three compartments and outlet gates suitable for soda ash and potash services. This car features the robust strength provided by a through center sill and can be furnished lined. Various roof hatch configurations are available.

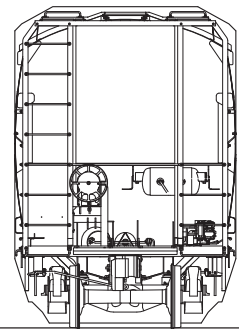

There are three different types of roof arrangements on the car:

- 1) Continuous trough (37' 6") (shown)
- 2) Segregated troughs (3 x 10' 4")
- 3) 30" dia. circular hatches

